

ELECTRIC MACHINES

DIRECT CURRENT

ALTERNATING CURRENT

ELECTROMAGNETIC BRAKES

EXCITERS FOR TURBO-GENERATORS

KI.10.2012

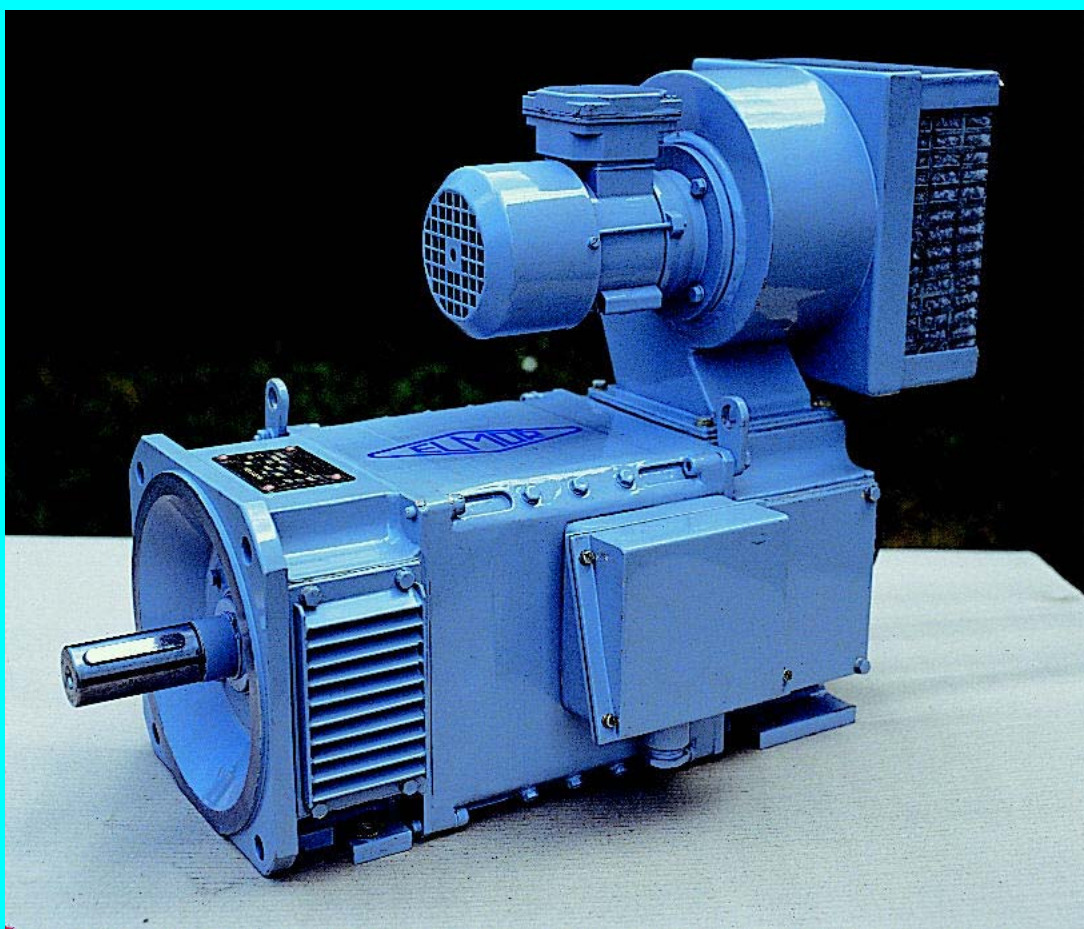

Certified acc. to
ISO 9001:2000



ISO 9001
Akredytacja PCA



OVERHAULS OF MACHINES AND ELECTRIC DRIVES

Specialization of **ELMOR S.A.** is not only production of electric machines and drives but also complete overhauls of dc and ac machines. We repair machines of polish and foreign production of voltages up to 1 kV:

- dc motors up to 100 kW
- dc generators up to 100 kW
- ac generators up to 160 kVA
- induction squirrel-cage motors up to 400 kW
- wound-rotor induction motors up to 160 kW
- electromagnetic disc brakes

We are able to a project and to perform modifications of some parameters (e.g. power, voltage, rpm) of machines and 1-phase and 3-phase transformers (atypical voltages). We apply pressure-vacuum impregnation of insulation classes B, F and H. We make coils (e.g. for brakes) as monoliths (resin castings). Rotary part of machines are static and dynamic balanced.

Before beginning an overhaul we make a calculation and submit it for Customer's acceptance. Time of overhaul realization depends on type of a machine and a scope of works; it is always agreed with the Customer.

All machines repaired by us are tested and they receive the Quality Department Attest.

Guaranty time is 12 months from the day of starting-up a machine but not longer than 18 months from a date of delivery the device to the Customer.

Thanks to many years' experience in production of machines and electric drives provided for ships of unrestricted sailing range we assure high overhaul quality of machines and equipment working in various climatic conditions (high quality of electrolytic and paint coats).

DC ELECTRIC MACHINES OF GENERAL USAGE

APPLICATION

DC motors and generators produced by **ELMOR S.A.** are provided for operation at sea and land in various climate conditions.

TECHNICAL CHARACTERISTIC

Various types of fixing are possible (on feet, with a flange for horizontal operation, with flange for vertical operation, on feet with flange for horizontal operation). Various kinds of excitation are available (shunt excitation, compound excitation, series excitation). Insulation class B or F.

Motors are made with a brake or without as drip-proof (IP22) and splash-proof (IP44, IP55, IP56). Generators are made as drip-proof (IP22); they are equipped with condensers, which together with windings of commutating poles create an interference eliminator. They can be driven by petrol motors, diesel engines, electric motors, etc.

TECHNICAL PARAMETERS

Generators

Powers are given for operation S1; voltage 115V or 230V; protection degree IP22.

Mechanical size	Power rating	Rated rotational speed
	[kW]	[rpm]
„2”	0,9 to 3,4	1450
„3”	2,4	1450
„4”	5,5	1450
„5”	7,8 to 13,2	1450
„6”	10,8 to 15	1450
„7”	18 to 26,4	1500
„8”	25,2 to 60	1500

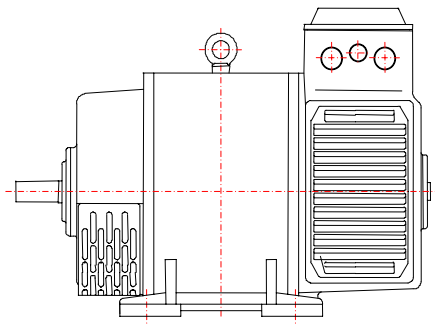

Machine type PKM

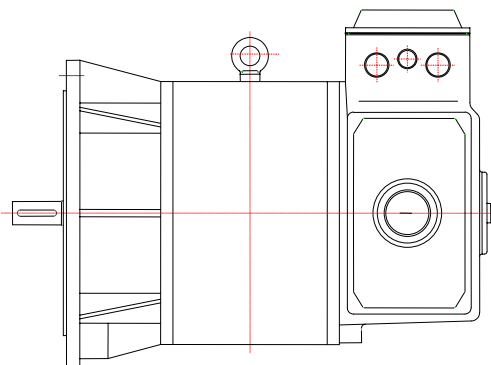

Machine type PSMP

Drip-proof motors

Powers are given for operation S1; Voltage 110V or 220V; Protection degree IP22.

Mechanical size	Power Rating	Rated rotational speed	
	[kW]	[rpm]	
„1”	0,6 to 1,32	1450	2900
„2”	0,9 to 3,12	950	1450 2900
„3”	1,92 to 5,52	950	1450 2900
„4”	6,0 to 9,36	1450	2900
„5”	6,0 to 9,0	950	1450
„6”	19,2	1450	
„7”	28,8	1450	
„8”	16,8 to 57,6	950	1450

Splash-proof motors

Powers are given for operation S1; Voltage 110V or 220V; Protection degree: IP44, IP55, IP56.

Mechanical size	Power Rating	Rated rotational speed	
	[kW]	[rpm]	
„1”	0,24 to 0,76	1450	2900
„2”	0,42 to 1,32	950	1450 2900
„3”	0,72 to 2,16	950	1450 2900
„4”	1,2 to 4,32	950	1450 2900
„5”	1,8 to 3,6	720	950 1450
„6”	4,32 to 7,2	950	1450
„7”	5,4 to 7,2	720	950
„8”	10,8 to 22,8	950	1450

We are able to make machines adapted to individual requirements of customers and perform modifications of some technical parameters (e.g. voltage - 440 V).

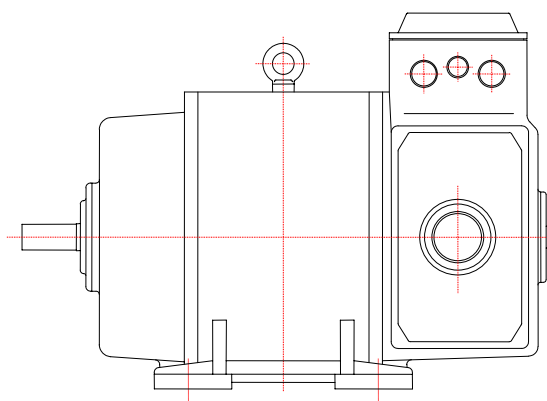

Machine type PSM

Individual machines are marked with symbols consisting of letters and figures of following meaning:

- | | | |
|---|----------------------------------|--|
| Letter on 1 place: | P | - dc machine |
| Letter on 2 place (type of housing): | K | - drip-proof |
| | S | - splash-proof |
| Letter on 3 place (type of excitation): | B | - shunt |
| | M | - compound |
| | S | - series |
| Letter on 4 place (type of fixing): | P | - flange fixing for horizontal operation |
| | V | - flange fixing for vertical operation |
| | T | - flange fixing on feet for horizontal operation |
| | No letter on 4 place means | - fixing on feet |
| Small letter: | - a, b, z | - construction series |
| Figure on 1 place (1 to 8): | | - mechanical size |
| Figure on 2 place (2 or 4): | | - number of poles |
| Marking after numerical part: | - a, b, x, y | symbol of length ferromagnetic sheets packet |
| | - number after sign " / " | - following mechanical execution for mechanical size |

Example of marking: **PKMTa54b/101** - drip-proof dc machine of series "a" with compound excitation and flange fixing on feet for horizontal operation with four main poles of number 101, mechanical size 5.

TRACTION MOTORS

APPLICATION

Motor type DK210A3P provided for driving of trolley buses.

Motor type PRAZa160 provided for driving of a pump, alternator and compressors in a trolley bus.

Motor type PRSZx64y/2 provided for driving of tramways. It is adapted for operation in driving systems with pulse adjustment.

TECHNICAL CHARACTERISTIC

Traction motors are self-ventilated. Supply cables are led out through glands.

Motor type DK210A3P is adapted to longitudinal independent suspension with transmission of a

torque by a cardan shaft and gear. It is supplied from a contact line. Protection degree is IP20.

Motor type PRAZa160 is mounted by means of feet with transmission of a torque by a pulley. It is supplied from a contact line. Protection degree is IP22.

Motor type PRSZx64y/2 is adapted to a longitudinal suspension on a truck with transmission of a torque by a cardan shaft and gear. The motor is equipped with an induction sensor for rotational speed measurement what enables control and elimination of a slip. Special construction of a brake drum ensures necessary flow of cooling air. Protection degree is IP22.

TECHNICAL PARAMETERS

Motor type	Rated power for operation S1	Rated voltage	Rated rotational speed (max)	Insulation class	Shaft end	Winding kind
	[kW]	[V]	[rpm]			
DK210A3P/3	90	550	1500(3900)	F/H	cone	shunt
DK210A3P/11						compound
DKZ10A3P/21						series
PRSZx64y/2	40	300	1890(4200)	H	cone	series
PRAZa160S/1	3	550	2100	B	cone	compound
PRAZa160M/1	6				cylinder	
PRAZa160M/2					cone	

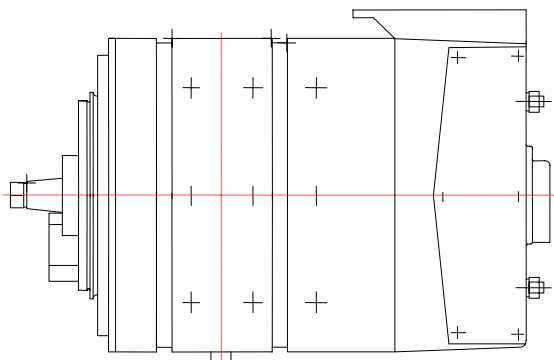

Motor type PRSZx64y/2

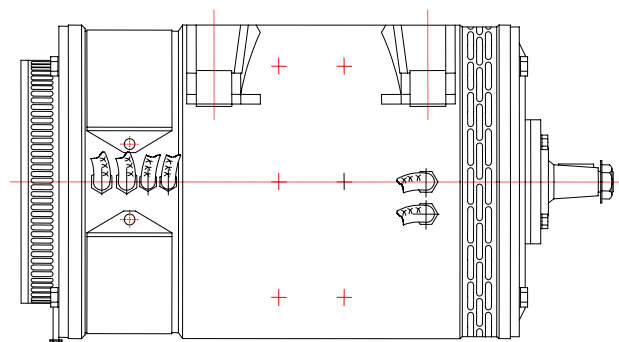

Motor type DK210A3P

DC CONTROL-SPEED MOTORS

APPLICATION

The DC control-speed motors for drives type Pg112 are destined to supply via frequency converters and are fitted with equipment where speed regulation is required (lathes, sugar diffusers). Motors type Pg112 is mostly destined for main propulsions of lathes with digital management. It is also found in various type of industry propulsions where double-zone motor speed control with wide range is required.

with the other technical parameters and additional equipment (resolver, air filter, temperature sensor, antiradioelectric filter). Protection degree is IP22.

TECHNICAL CHARACTERISTIC

Motors have extorted cooling by over built blower that is driven by three phase motors and are applied with tacho-alternator that is mounted at the other end of shaft. The motor type Pg112 is four polar machine, other-excite with polar commutation and compensation wire. The stator tetrahedron frame less is whole plated. It is possible to make motors

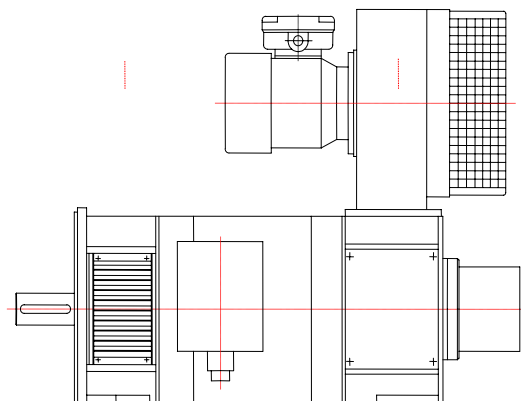

Motor type PG

TECHNICAL PARAMETERS

Motors type „Pg”

Motor type	Rated power for operation S1	Rated torque	Rated rotational speed	Rotational speed (max)	Inertial torque
	[kW]	[Nm]	[rpm]	[rpm]	[kgm ²]
Pg112F	1,5	28,7	500	5000	0,035
	2,2	28,0	750		
	3,7	28,7	1000		
	5,5	35	1500		
Pg112E	2,2	42,1	500	5000	0,045
	3,0	38,2	750		
	5,0	38,2	1000		
	7,5	47,8	1500		
Pg112E	3,0	57,4	500	5000	0,063
	5,5	70,1	750		
	7,3	67,9	1000		
	11,0	70,1	1500		

Armature voltage 375 V, induction voltage 180 V, type of operation S1, protection degree IP22.

Motor type	Rated power	Rated voltage	Rated current	Rated rotational speed	Range of control rotational speed
	[kW]	[V]	[A]	[rpm]	1:100
PCOzMI4/4-MIS1	14	440	39	2800	1:25
PCOaM40/4-MIS	40	375	125	1400	1:5
PRBZz315s/7	60	440	185	1500	1:5
PRBZz315s/8	30	440	85	1500	1:5
PRAZa315s/12	55	220	285	1500	1:5

INDUCTION THREE-PHASE MULTIPLE-SPEED SQUIRREL-CAGE MOTORS WITH DISC BRAKES

APPLICATION

Multiple-speed motors are provided for driving of mooring winches, windlasses and cargo facilities. They are adapted for assembly on open deck of ships of unrestricted sailing range.

TECHNICAL CHARACTERISTIC

Motors have three or four (depending on type and execution) rotational speed stages in both directions. Temperature sensors are located in each end winding. They switch off this winding, which has reached a temperature-rise limit admissible for the

applied insulation class. Anti-condensing heating tapes (located in end windings) which prevent moisture condensation, heating the windings when motor is not running increase reliability of the drive.

Electro-magnetically released disc brake is built-in on the opposite side to the drive. It is possible to apply the field forcing (by means of a system contained in driving devices). Construction of the brake enables its manual release.

Forced external cooling has been applied in motors type hSSDa and bSSDa. Fan together with its driving motor is located in a ventilation box under a main engine.

TECHNICAL PARAMETERS

Motors type hSSDa

Rated power	Rated current	Rated rotational speed	Rated Torque	Starting torque multiplicity	Starting current
[kW]	[A]	[rpm]	[Nm]	[-]	[A]
Supply voltage 3x380 V, 50 Hz					
2,6/19/38	52/60/88	110/720/1440	225/252/252	1,66/2,2/2,1	63/156/390
3/19/38	45/70/82	110/720/1420	260/252/252	1,73/2,3/1,67	48/156/242
8,3/19/38	28/60/88	325/720/1440	244/252/252	1,7/2,2/1,9	48/156/390
Supply voltage 3x440 V, 60 Hz					
3,4/19/38	56/60/85	133/850/1764	244/214/206	2,35/3,1/2,68	40/155/390
3,4/19/38	35/60/73	133/860/1750	244/211/207	2,5/3,0/2,2	40/150/258
9,3/19/38	25/60/85	415/850/1764	214/214/206	2,7/2,9/2,7	43/155/390

Motors type bSSDa

Rated power	Rated current	Rated rotational speed	Rated Torque	Starting torque multiplicity	Starting current
[kW]	[A]	[rpm]	[Nm]	[-]	[A]
Supply voltage 3x380 V, 50 Hz					
6,6/31/63	77/80/120	153/725/1470	412/412/412	1,6/2,3/1,8	91/360/770
6,6/31/63/63	77/80/120/115	153/725/1470/2950	412/412/412/206	1,6/2,3/1,8/1,6	91/360/770/820
Supply voltage 3x440 V, 60 Hz					
7/31/63	60/54/105	200/890/1763	333/333/343	2,2/1,6/2,2	89/410/850
7/31/63/63	60/54/105/100	200/890/1763/3470	333/333/343/172	2,2/1,6/2,2/1,7	89/410/850/900

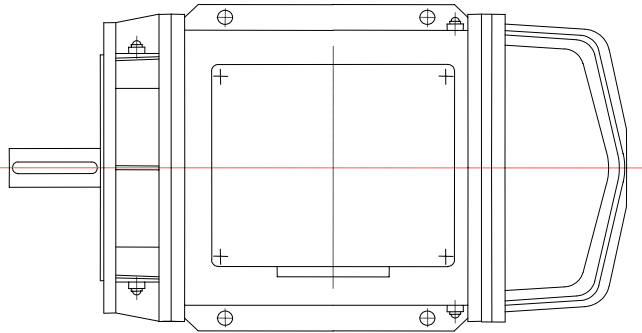

Motor type MD3Sa40

Motors type MD..Sa

Rated power	Rated current	Rated rotational speed	Rated Torque	Starting torque multiplicity	Starting current
[kW]	[A]	[rpm]	[Nm]	[-]	[A]
MD1Sa38					
Supply voltage 3x380 V, 50 Hz					
2,9/18/38	40/62/86	110/680/1450	252/252/250	1,7/2,2/2,3	48/149/378
2,9/18138138	40/62/86/76	110/680/1450/2900	252/252/250/125	1,7/2,2/2,3/2,5	48/149/378/403
Supply voltage 3x440 V, 60 Hz					
4/18/38	40/56/81	180/810/1650	212/212/220	1,2/2,2/2,3	48/134/356/392
4/18/38/38	40/56/81/74	180/810/1650/3390	212/212/220/105	1,7/2,2/2,3/2,5	48/134/356/392
MD2Sa38					
Supply voltage 3x380 V, 50 Hz					
2,9/21/38/19	34/56/82/41	94/702/1455/2910	290/290/255/62	1,7/2,1/2,1/3,6	53/179/412/464
Supply voltage 3x440 V, 60 Hz					
4,1/21/38/19	36/51/71/35	160/870/1784/3550	250/235/207/52	1,8/2,2/2,4/4,7	43/170/510/520
MD3Sa40					
Supply voltage 3x380 V, 50 Hz					
9,2/40/20	59/76/38	340/1460/2950	260/260/65	2,1/2,2/1,7	95/312/230
Supply voltage 3x440 V, 60 Hz					
9,2/40/20	52/68/33	400/1750/3550	220/220/55	2,3/2,2/2,1	93/300/220
MD4Sa45					
Supply voltage 3x380 V, 50 Hz					
11/45/25	80/86/46	340/1460/2940	300/300/80	1,8/2,5/1,5	105/430/260
Supply voltage 3x440 V, 60 Hz					
11/45/25	67/77/42	420/1740/3500	250/250/70	2,2/2,4/1,6	110/440/270
MD7Sa30					
Supply voltage 3x380 V, 50 Hz					
7,3/30/15	49/61/31	348/14621/2952	200/200/48	2,3/2,4/1,4	93/330/190
Supply voltage 3x440 V, 60 Hz					
7,3/30/15	45/53/27	426/1767/3560	164/164/40	2,4/2,5/1,6	85/325/186

Individual machines are marked after symbol (example MD3Sa40) and first sign " / " in following kind:

- first place: number of rotation speed (3 or 4)
- second place: kind of bearing lubrication from propulsion machinery side:
 0 - lubrication by oil from gear box
 1 - lubrication by solid lubricant (special order)
- number after sign " - ": supply voltage parameters:
 1 - supply voltage 3x380V, frequency 50Hz
 2 - supply voltage 3x440V, frequency 60Hz
- number after second sign " / " following mechanical execution

Example of marking: **MD3Sa40/30-1/01** - motor type MD3Sa40 with three rotation speed levels, with bearing from machinery side, lubricated by oil from gear box, supplied voltage 3x380V with frequency 50Hz, mechanical size number 01.

ELECTRO-MAGNETICALLY RELEASED DISC BRAKES

APPLICATION

Brakes of series "Z" are provided for braking and releasing of dc and ac electric motors driving the transport facilities on sea-going and inland ships of unrestricted sailing range. They can be applied on land in various branches of industry, too.

TECHNICAL CHARACTERISTIC

Brakes are supplied with dc current. Their protection degree is IP56, execution can be marine type (Z, ZS, ZF) and land type (ZL). In case of power failure or damage of the electric installation, construction of the brake allows for its manual release.

Types of execution:

ZS - with manual release lever

ZF - with forcing of the coil supply voltage

ZL - for land application.

TECHNICAL PARAMETERS

Brake type	Braking moment	Supply voltage	Current	Time of armature attraction	Time of armature fall off
	[Nm]	[V]	[A]	[s]	[s]
Z2,5	25	110	0,73	0,2	0,1
ZL,3,2/11	32	340	0,27	0,4	0,12
ZL3,2/31	32	110	0,73	0,4	0,12
ZL10/1	98	340	0,27	0,45	0,18
ZL10/2	98	450	0,187	0,45	0,18
ZL10/3	98	110	0,9	0,4	0,18
Z10 or ZS10	100	110	0,63	0,4	0,15
Z16 or ZS16	157	110	1,1	0,35	0,2
ZF16	157	220/45	0,32	0,35	0,2
Z25 or ZS25	245	110	0,85	0,5	0,3
ZF25	245	220/40	0,51	0,2	0,13
Z40 or ZS40	400	110	1,96	0,5	0,4
ZF40	400	220/35	1,4	0,25	0,15
Z63 or ZS63	630	110	1,96	0,8	0,4
ZF63	630	220/35	1,4	0,25	0,15
Z100 or ZS100	980	110	4,3	0,5	0,25

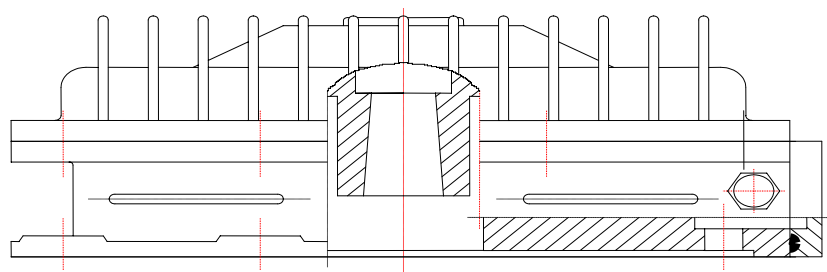

Brake type Z16

SELF-EXCITED SYNCHRONOUS GENERATORS

GENERATORS TYPE GDPBa and GTNSa

APPLICATION

Self-excited synchronous generators of small power are provided for generating of ac electric energy in generating sets.

TECHNICAL CHARACTERISTIC

Single-phase generators of type GDPBa are brushless machines with built-in voltage regulator (addi-

tional windings co-operating with a condenser fixed outside the generator).

Three-phase generators of type GTNSa are brush machines with a voltage regulator located in a separate box. In the box there are also: voltmeter, overload switch and 1-phase and 3-phase socket.

Way of coupling with a driving motor depends on motor connection.

Fixing of generators: by means of flanges or flanges with feet support.

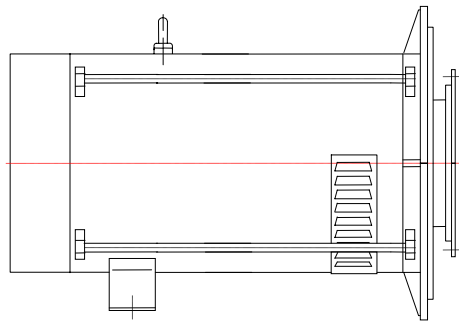

Generator type GTNSa132

TECHNICAL PARAMETERS

Rotational speed: 3000 rpm

Frequency: 50 Hz

Generator type	Rated power	Rated current	Insulation class	Protection degree	Efficiency	Bearings
	[kVA]	[A]			[%]	
Rated voltage 220 V , power factor 1,0						
GDPBa 132M/O1	6,5	29,5	H	IP44	68	1-bearing
GUPBa 132M/O2	6,5	29,5	H	IP22	69	1-bearing
Rated voltage 3x380 V , power factor 0,8						
CTNSa 132S2/03	6,5	9,9	F	IP22	76	2-bearing
GTNSa132S2/05	6,5	9,9	H	IP44	78	1-bearing
GTNSa132M2/03	12,5	19,0	F	IP22	78	2-bearing
CTN5a132LA2/06	15,0	22,8	H	IP22	80	1-bearing
CTN5a132LB2/06	20,0	30,4	H	IP22	80	1-bearing

GENERATOR TYPE GCf 74

APPLICATION

Three-phase self-excited generator type GCf-74 serves for generating the electric energy in ac generating sets and is provided for operation on land.

TECHNICAL CHARACTERISTIC

This machine is equipped with a built-in system for automatic regulation of voltage. It is adapted for operation in horizontal position with feet fixing. It is connected with a motor by means of a coupling.

TECHNICAL PARAMETERS

Rated power	Rated current	Rated voltage	Rotational speed	Frequency	Insulation class	Protection degree	Efficiency
[kVA]	[A]	[V]	[obr/min]	[Hz]			%
20	29	3x400	1500	50	B	IP20	84

GENERATORS TYPE Gcf, GCh, GTN

APPLICATION

Three-phase self-excited synchronous generators co-operating with voltage regulation systems type WS are provided for generating the ac electric energy in generating sets installed on ships of unrestricted sailing range. They can be applied in generating sets working on land, too.

TECHNICAL CHARACTERISTIC

Generators are adapted for driving by means of combustion-piston engines connected with them by

a coupling. They are manufactured in two versions of fixing - on feet or with flange on feet support.

Voltage regulation system type WS co-operating with the generators are produced in following executions:

WS - in a housing (protection degree IP22); adapted for fixing on a support construction

WS...T - without housing (protection degree IP00); adapted for building-in.

TECHNICAL PARAMETERS

Voltage: 3x400/231 V;

Frequency: 50 Hz;

Rotational speed: 1500 rpm

Type of generator and regulator	Rated power	Rated current	Power factor	Insulation class	Protection degree	Efficiency
	[kVA]	[A]				[%]
GCB4c/5 + WS55P	55	80	0,8 ind.	B	IP22S	87
GCB4d8 + WS55	45	65	0,8 ind.	B	IP22S	90
GCPB4c/9 + WSSSP	55	80	0,8 ind.	B	IP22S	87
GCPB4d101 + WS55	45	65	0,8 ind.	B	IP23	90
GCPt'94c/1 + WS60N/1	60	87	0,8 ind.	B	IP22	
GCh114/4 + WS125/3	125	180	0,8 ind.	B	IP23	
GTNE250/1 + WS125/3	125	180			IP22	

On special requests we make generators for voltage 3x450/260V and frequency 60Hz (1800 rpm). In such case the generator power can be increased by 17% in ratio to the frequency 50Hz.

GENERATORS TYPE Gck

APPLICATION

Self-excited, brush-less synchronous generators of increased moment of inertia, which co-operate with voltage regulation thyristor systems type RNGY41 are provided for generating the ac electric energy in generating sets installed on ships of unrestricted sailing range. They can be applied in moveable and stationary generating sets working on land.

TECHNICAL CHARACTERISTIC

Thanks to their features the generators are widely applied in generating sets, which are used in difficult operating conditions.

They have small values of transient synchronous reactance thanks to special shape of induction field in an air-gap forming a trapezoid. This allows for limiting the value of voltage changes on generator terminals after sudden load switching on.

Moment of inertia of a rotating part is ~10 times bigger in ratio to the inertia moment of the generators made on traditional way. It eliminates irregularity of the combustion engine running without necessity to use a flywheel.

Generators of type GcK are made in several construction versions ensuring high universality of a product:

- GcKF265 - 1-bearing construction; flange fixing; direct coupling with a driving motor
- GcKL94 - 1-bearing construction; flange fixing with feet support; direct coupling with a driving motor
- GcK94 - 2-bearing construction; fixing on feet, connection with a driving motor by means of a coupling
- GcK../21 - generator with a regulator.

Voltage regulation systems type RNGY41 co-operating with generators are made in several construction versions depending on application of the generating set:

- RNGY41 S - regulator provided for operation in stationary generating sets; it is located in metal housing adapted for hanging
- RNGY41 W - regulator adapted for assembly into a switchboard; it is made as a board equipped with individual sub-assemblies; without housing
- RNGY41 R - regulator with a distribution-measure part for consumers and a control part for driving motors.

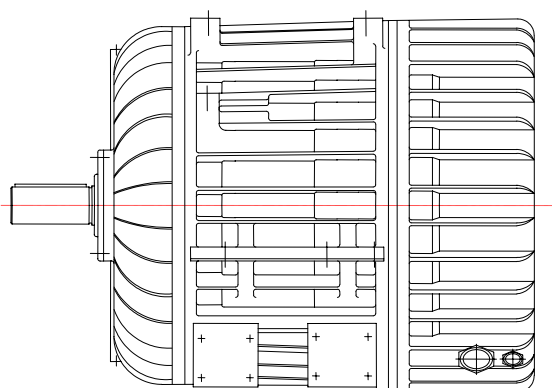

Generator type GcK94/21

TECHNICAL PARAMETERS

Generator type	Rated power	Rated current	Power factor	Insulation class	Protection degree	Efficiency
	[kVA]	[A]				%
3x400/231 V; 50 Hz; 1500 rpm						
GcK...S	25,0	36,0	0,8 ind.	B	IP22	85
GcK...M	37,5	54,0				87
GcK...L	62,5	90,0				90
3x450/260 V; 60 Hz; 1800 rpm						
GcK...S	28,0	36,0	0,8 ind.	B	IP22	85
GcK...M	43,0	55,0				87
GcK...L	71,0	91,0				90

On special requests we make generators for voltage 3x220V, 50Hz.

EXCITERS FOR TURBO-GENERATORS



Exciter type WBE8-5G



Exciter type WBE6-4k

APPLICATION

ELMOR S.A is a producer of brush-less exciters for turbo-generators of power 68÷80 MW produced by the Company ALSTOM Power. Production is based on documentation supplied by a Customer and exciters are manufactured to the high technological regimes.

TECHNICAL CHARACTERISTIC

Exciter armature together with the rectifier system is assembled on a turbo-generator shaft. Thanks to such solution the excitation voltage is given directly to the winding of generator excitation without necessity to apply the slip rings.

Exciters type WBE are equipped with bearing and exciters type WBF are bearing-less.

TECHNICAL PARAMETERS

Exciter type	Rated power	Rated voltage	Frequency	Rated current	Rotational speed	Insulation class	Protection degree
-	[kW]	[V]	Hz	[A]	[r.p.m.]	-	-
WBE8-5G	563	375	60	1500	3600	F	IP44
WBE6-4k	364	310	50	1175	3000	F	IP44
WBF6-4k	364	310	50	1175	3000	F	IP44



ELMOR S.A.

ul. Spadochroniarzy 20, 80-298 Gdańsk, Poland

TEL: +48 (58) 763-44-88; 785-36-70

+48 (58) 762-93-64; 785-36-77

FAX: +48 (58) 762-93-19

+48 (58) 785-36-79

e-mail: elmor@elmor.com.pl

Website: <http://www.elmor.com.pl>

Management Board

Marketing Department

Management Board

Marketing Department